



VCL-0432

VCL Gigabit Ethernet over SDH (STM1)

Introduction:

VCL-GigEoSDH is a dual - VCG channel Gigabit Ethernet Converter, provides 4 gigabit Ethernet interfaces (3copper and 1 fiber Ethernet interfaces) compliant with IEEE 802.3 series standard and 2 STM-1 optical interfaces, supports 1+1 optical path protection and 2+0 mode. In 1+1 mode, the 4 Ethernet interfaces share one VCG and the bandwidth is one VC4 (139Mb/s). In 2+0 mode, the 4 Ethernet interfaces share two VCG channels and the bandwidth is two VC4. Therefore, By GFP and EoS technology, VCL-GigEoSDH can realize two 139Mb/s Ethernet traffic transmission over STM-1 optical line.



NE Management

- Supports Simple Network Management Protocol (SNMP), compatible with V1 and V2C protocol
- Supports FTP protocol and firmware download online without disturbance of existing traffic
- Monitoring the alarms and status in real-time

Application Diagram: Point to Point Application

VCL-GigEoSDH supports point-to-point application. In 1+1 mode, the 4 Ethernet interfaces share one VCG and the bandwidth is one VC4 (139Mb/s). In 2+0 mode, the 4 Ethernet interfaces share two VCG channels and the bandwidth is two VC4. Refer to section 5.3 for more.

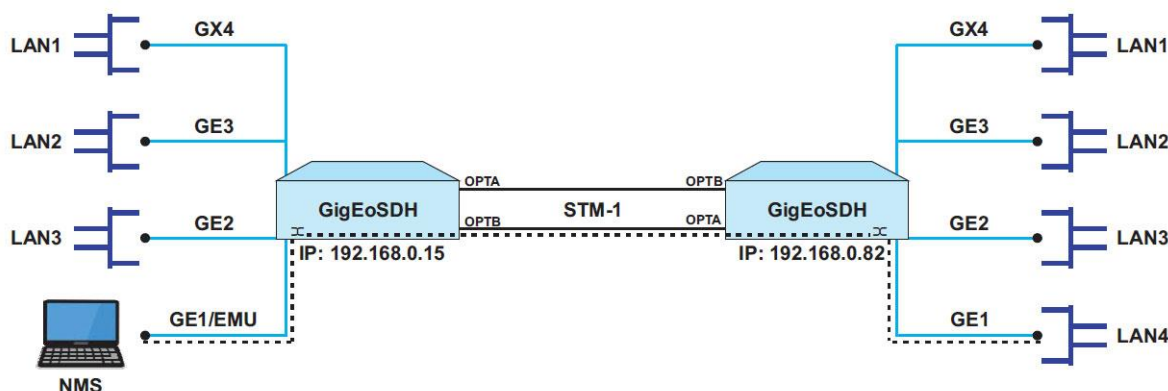

Note: Make sure optical A of one NE must be connected with optical B of its neighbouring NE.

Features:

- Compact design with 1U height, 19 inch, 155mm depth, and can be installed on standard rack
- Loop back
 - Supports VC4 channel of STM-1 optical loopback towards line side
- Supports 1+1 path protection and Automatic Protect Switch (APS) with switching time less than 50ms
- Supports 2+0 mode, the transmission bandwidth available can be up to 2 VC4
- Compliant to ITU-T standards
 - GFP-F encapsulation, compatible with ITU-T G.7041 recommendation
- Supports hot-spare power, the power consumption is less than 10W
 - 48V DC single power access
 - 220V AC single power access
 - 48V DC+220V AC double power access

System Management

- VCL-GigEoSDH supports management via CLI command based on serial RS232 port (CONSOLE) and telnet (EMU interface).
- VCL-GigEoSDH also supports network management platform based on SNMP (V1 and V2C) to complete configuration management and kinds of alarm monitoring.

Note: The IP address of PC and the equipment should be in the same IP network segment.

Optical interface:

- Two STM-1 optical interfaces; SFP optical module (LC interface); Hot pluggable
- The line bit rate is 155Mb/s, single mode, transmission distance is optional (depend on the SFP optical module)
- Supports real-time detection for the status of optical module
- Supports Automatic Laser Shutdown(ALS) to protect operators from hurt
- Supports Remote Power down Detect (RPD) function

Ethernet interface:

- One fiber gigabit Ethernet interface and three copper gigabit Ethernet interfaces compliant with IEEE802.3 serial standard;
- The copper gigabit Ethernet interfaces adopt RJ45 connector, support auto-negotiation, which can work in 1000M full-duplex, 100M full/half-duplex, 10M full/half-duplex mode; supports auto MDI/MDX function
- The fiber gigabit Ethernet interface adopts 1.25G SFP module, which can work in 1000M full-duplex mode, transmission distance is optional (depend on the SFP optical module)
- Provides two WAN port (inside and invisible), each corresponding to one VCG separately, the bandwidth of each VCG is a VC4.

Management Interface

- Any of the GE1-3, GX4 can be used as the Ethernet management interface (EMU)
- Provides one serial management interface (CONSOLE)
- Supports embedded DCN management channel to achieve inband management

Ethernet Switch Bridge

- Supports unicast, multicast and broadcast frame
- 8K MAC address table, with optional 12s / 300s ageing time configurable, the default is 300s
- Supports MAC address dynamic learning function
- Supports 256 items static MAC address configuration
- Accepts frames with length between 64 and 1552/2048 bytes (otherwise filtering)
- Supports port-based VLAN and IEEE802.1Q tag-based VLAN
- Supports QinQ (Double Tag VLAN)
- Supports up to 4K items VLAN table
- Supports Link Aggregation for WAN and LAN port, supports up to 4 link aggregation groups
- Supports IEEE 802.1P QoS
- Supports Port Mirroring
- Supports Dynamic ARL Table Learning and Searching
- Supports port rate control
- Provides performance statistic for each Ethernet interface.

Hardware Specification:

- | | | |
|---------------------|---|-------------|
| • Width | = | 480mm |
| • Depth | = | 210mm |
| • Hight | = | 045mm |
| • Weight | = | < 2.8kg |
| • Power Consumption | = | < 12watts |
| • MTBF | = | > 30+ years |

Ordering Information

VCL-Gigabit Ethernet over SDH (STM-1) Common Equipment:
CORE UNIT without PSUs

Part #	Product Description
VCL-0432-GigE	<p>VCL-Gigabit Ethernet over STM-1 (VC4) 19-inch 1U High Rack Mount version</p> <p>Supports :</p> <ul style="list-style-type: none"> – 4 x Gigabit Ethernet Port (2VCG, 2 Channel) – 3 x Electrical Ethernet Port [RJ45 (F)] – 1 x Optical Ethernet Port [SFP based - without SFP] – 2 x STM-1 (VC4) Ports (1+1) [SFP based - without SFPs] – 1 x System Core Cables, Installation accessories, Documentation, System User Manual/ Disk etc. (Set) – OAM: EOW, SNMP, EMS, NMS <p>* Add Power Supply Option from below</p>

Power Supply Options (Any one Option)

S. No.	Option	Description
1	AC220	1 x 100-240V AC Power Supply Input
2	DC048	1 x 48V DC Power Supply Input
3	ACDC	1 x 100-240V AC Power Supply Input 1 x 48V DC Power Supply Input

Gigabit SFP Options (Maximum 1 SFP per 1ETH-4VCG-O)

S. No.	Option	Description
1	VCL-EMOD 0231	1.25Gbps SFP Transceiver Duplex LC, 1310nm, 15Km, SMF
2	VCL-EMOD 0255	1.25Gbps SFP Transceiver Duplex LC, 1310nm, 40Km, SMF
3	VCL-EMOD 0256	1.25Gbps SFP Transceiver Duplex LC, 1550nm, 80Km, SMF

STM-1 SFP Options (Maximum 2 SFPs per CORE UNIT)

S. No.	Option	Description
1	VCL-EMOD 0193	155Mbps SFP Transceiver, SDH/STM-1, SONET/OC-3, Fast Ethernet, S-1.1, Duplex LC, 1310nm, 15Km, SMF
2	VCL-EMOD 0194	155Mbps SFP Transceiver, SDH/STM-1, SONET/OC-3, Fast Ethernet, L-1.1, Duplex LC, 1310nm, 40Km, SMF
3	VCL-EMOD 0217	155Mbps SFP Transceiver, SDH/STM-1, SONET/OC-3, Fast Ethernet, L-1.2, Duplex LC, 1550nm, 80Km, SMF
4	VCL-EMOD 0156	155Mbps SFP Transceiver, SDH/STM-1, SONET/OC-3, LR-2/LR-3, Fast Ethernet, L-1.2, Duplex LC, 1550nm, 120Km, SMF
5	VCL-EMOD 0243	155Mbps SFP Transceiver, SDH/STM-1, SONET/OC-3, L-1.2, Duplex LC, 1550nm, 150Km, SMF

Cable and Accessories Options (As per Site requirement)

S. No.	Option	Description
1	VCL-HRNS 1229	Optical Patch Cord Connectorized Cable [2LC-2LC, 3m, SM]
2	VCL-HRNS 1238	Optical Patch Cord Connectorized Cable [2LC-2LC, 10m, SM]
3	VCL-HRNS 1242	Optical Patch Cord Connectorized Cable [LC-FC, 10m, SM]
4	VCL-HRNS 1243	Optical Patch Cord Connectorized Cable [2LC-2FC, 10m, SM]
5	VCL-HRNS 1239	Optical Patch Cord Connectorized Cable [LC-SC, 10m, SM]
6	VCL-HRNS 1258	Optical Patch Cord Connectorized Cable [2LC-2SC, 10m, SM]
7	VCL-ECON 1172	Connector (Attenuator LC-LC (10 db.))
8	VCL-ECON 1173	Connector (Attenuator LC-LC (20 db.))
9	VCL-ECON 1186	Connector (Attenuator FC-FC (10 db.))
10	VCL-ECON 1187	Connector (Attenuator FC-FC (20 db.))
11	VCL-ECON 1197	Connector (Attenuator SC-SC (10 db.))
12	VCL-ECON 1198	Connector (Attenuator SC-SC (20 db.))

Note: Operation and maintenance of network equipment require professional knowledge and experience. We recommend the equipment to be managed only by qualified technicians. Should you require technical assistance please consult the provider, or contact our SUPPORT DESK at support@cxr.com



CXR
 17 Rue de l'Ornette
 28410 ABONDANT – France –
 Tel:+33(0)2.37.62.87.90
contact@cxr.com
<http://www.cxr.com>