

QUAD E&M VOICE CARD

FOR CXR QX3440



For QX3440 and QX3440C



For QX3440E

Features

- Five E&M signaling types are supported: Type I, Type II, Type III, Type IV, and Type V
- Jumpers selectable for Type I, II, III, IV, V or Tx only
- TO (Transmit Only) supported
- A-side and B-side supported: A-side is exchange side; B-side is carrier side
- User programmable A-law or μ -law coding
- User programmable loss adjustment
- User programmable balance 600/900 ohm impedance
- CAS signaling convention
- Jumper selectable: 2/4 WIRE, A/B SIDE
- Support diagnostic functions, including:
 - * off hook test
 - * loopback test
 - * LED display bit for signaling monitoring
- Intended for use with ± 48 , ± 125 Vdc or 100-240Vac powered main units.

Application

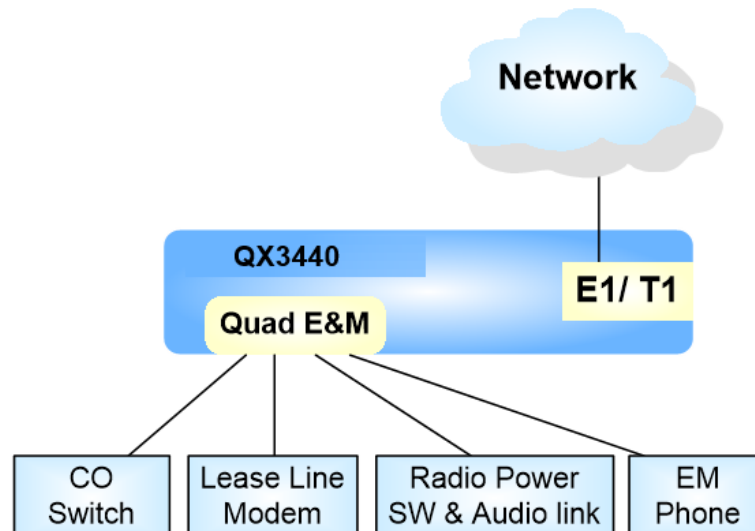

Description

CXR's QEMA plug-in card is designed for the QX3440. E&M provide user selectable A-law or m-law coding. The QX3440 QEMA card requires an external cable to support 4-RJ45 ports for connecting to PBX tie lines, carrier facilities, or 4-wire modems. Each RJ45 port has 8 pins supporting the following signaling and transmission pairs: E/M, SG/SB, T/R, and T1/R1.

The card can configure different types, A/B side and 2/4 wire options by jump location. Users can utilize additional jumpers enclosed in the package for Type I, II, III, IV, V and TO (Transmit Only) signaling options. Type TO provides dedicated 4-wire transmit and receive paths to lease-line modem equipment. There are choices of two side: Using A side mode, the card can operate as switching equipment. Using B side mode, the card can operate as channel equipment. There are 3 diagnostic functions supported: off hook test, loopback test, and LED display bit for signaling monitoring. Moreover, users could have LEDs provide channel setting and channel status indicators.

NOTE

The jumper version QEMA card has to work with QX3440 controller firmware v8.30.01 or up to support:

- a) 0.1dB step gain adjustment
- b) software configurable signaling bits
- c) trunk condition setting
- d) diagnostic functions
- e) side/wire/signaling/power display

Ordering information

Model	Description	Note
QX3440-QEM-xW-s-Tn	4 E&M 4 wire Voice Interface, plug-in module use mini slot of QX3440-C only , include cable DB25M to 4 RJ45. complied with IEEE1613 standard. x=2 or 4 wires, s = Side A or B, n = Type 1 to 5 Ex : QX34DD-QEM-4W-A-T5 = 4W, side A, type5 .	For QX3440 and QX3440C Not applicable to ± 24 Vdc powered main units.
QX34DD-QEMA-4w-A-Tn	Jumper selectable: 2/4 WIRE; A/B side Quad E&M voice card, complied with IEEE1613 standard. Indicate Tn for type (1,2,3,4 or 5).	For QX3440E Not applicable to ± 24 Vdc powered main units.

Product Specifications

Voice Card (QEMA)

Connector	One 44-pin connector, adapter cable included for 4 RJ45 connectors.
Alarm Conditioning	CGA busy after 2.5 seconds of LOS, LOF
Encoding	A-law or m-law, user selectable as a group
Impedance	Balanced 600Ω or 900Ω
Gain Adjustment (Per-port setting)	-10 to +7 dB / 0.1dB step for transmit (D/A) gain -10 to +14 dB / 0.1dB step for receive (A/D) gain
Gain Variation	± 0.5 dB at 0 dBm0 input
Frequency Response	± 0.5 dB from 300 to 3400 Hz, coincide with ITU-T G.712
I/O Power Range	A/D Analog input level: -66 dBm (0.00039 Vrms) ~ + 3 dBm (1.09 Vrms) D/A Analog output level: -66 dBm (0.00039 Vrms) ~ + 4 dBm (1.22 Vrms)
Longitudinal Balance	> 63dB
Longitudinal Conversion Loss	> 46dB
Total Distortion	> 35 dB at 0 dBm0 input
Idle Channel Noise	< -65 dBm0p
Wire Mode	2 wire and 4 wire
Signaling	Type I, Type II, Type III, Type IV, Type V, and also TO (Transmit Only)
M Lead Output Current	18 mA (maximum)
E Lead Sensor Current	0.3 mA (minimum)
EM Type Setting	Jump Selectable
Operational Temp.	0°C to +50°C
Relative Humidity	0% to 95%
Carrier Connection	Side A and side B setup by Jump

All in-band signaling tones are carried transparently by the digitizing process.

Customer is responsible for in-band signaling compatibility between a telephone and a switch, or between a PBX and a switch.

Compliance

FCC Part 68, CS-03 listed for connection to PSTN
NRTL safety listed: UL1459, CSA
ITU-T G.712



CXR
T +33 (0) 237 62 87 90
www.cxr.com

17 Rue de l'Ornette 28410 Abondant France
contact@cxr.com