

## HX 9100

### Overview of Protection Types

The purpose of this paper is to clarify for our customers the types of protection available with the HX 9100.

There are two main types of protection that can be used with the HX 9100. One is MSP (Multiplexer Section Protection) 1+1. Basically, in this type of protection an entire span (including all timeslots traveling on that span) is protected. For SDH that span is defined as a Multiplexer Section. For SONET it is defined as a line. The second type of protection is known as SNCP (Sub-Network Connection Protection). This is also called UPSR (Uni-directional Path-protection Self-healing Ring). Basically, in SNCP/UPSR protection, an individual tributary (dual-fed into different paths on the transmit side) can be protected by path selectors at the path termination points on the receive side.

In the sections below this paper will discuss signal transmission path and protection schemes in different topologies (ie. Network Element layouts) for the HX 9100. It will also discuss the relative merits of transmitting signals without protection, with MSP 1+1 protection, with SNCP/UPSR protection and with a combination of SNCP/UPSR and MSP protection.

### Configuration 1: Linear Topology Without Protection

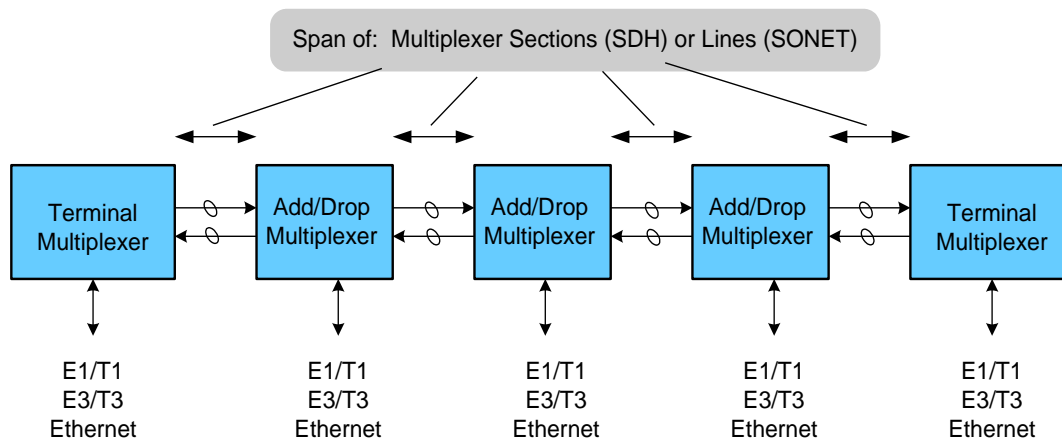

#### Who:

This configuration is very practical when there is a linear geographic limit to the client's NE (Network Element) layout, and fiber availability is limited.

#### Add/Drop Capacity:

TM = 63 E1 (The limit is determined by the STM-1 capacity);  
ADM = 112 E1 (The limit is determined by the 4 E1 cards add/drop capacity)

#### Advantages:

A simple, 2 fiber layout

#### Cost of Advantages:

No protection against fiber cut and circuit pack failure

## Configuration 2: Linear Topology With MSP (1+1) Protection

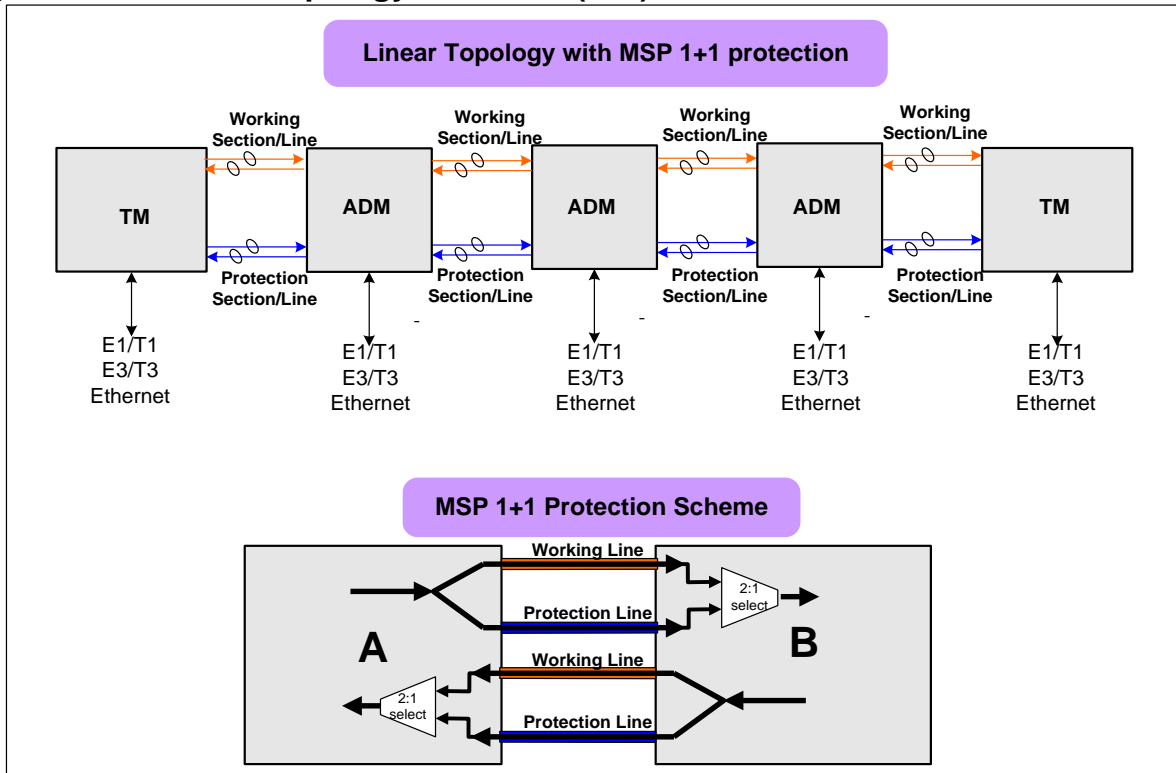

### Operation:

In the A→B direction, the whole outgoing payload is dual-fed into both the working section/line and the protection section/line at node A. The payloads from both sections are received at node B. Based on the integrity and algorithm provided by the Multiplex Section embedded inside the transport frame, only one of the payloads will be selected and used at node B. This is how MSP 1+1 works. Note that the paths or sub-channels within the Multiplexing Section are treated as a whole pipe, in terms of the MSP 1+1 protection. The whole payload selected is either from the working section/line or from the protection section/line.

### Who:

This configuration is ideal in a linear topology with spare fiber available. The client can benefit both protection against fiber cut and protection against circuit pack failure.

### Add/Drop Capacity:

TM = 63 E1's with MSP protection (The limit determined by the STM-1 capacity);

ADM = 112 E1's with MSP protection (The limit determined by the 4 E1 cards add/drop capacity)

### Advantages:

All tributary traffic is protected against fiber cut and optical circuit pack failure

### Cost of Advantages:

Four fibers are required. Maximum 63 E1's capacity at head ends (TMs)

### Note:

To achieve the best protection possible, the working fibers shall take different routes in different fiber bundles

### Configuration 3: Ring Topology with SNCP/UPSR Protection

#### STM-1 SNCP/UPSR Protection Architecture

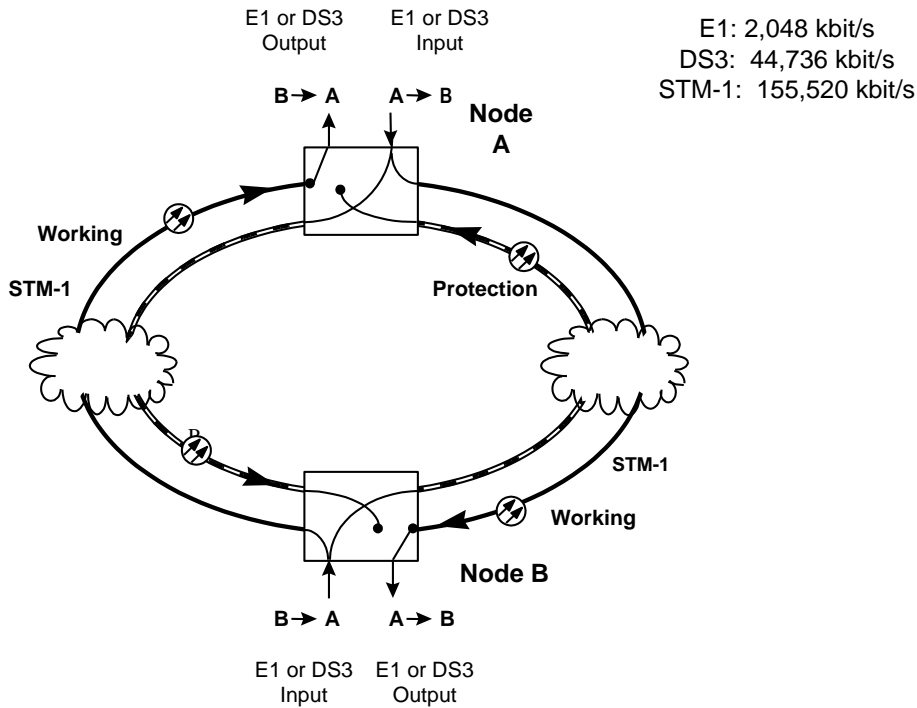

**Operation:**

In the B→A direction, at Node B the tributary traffic is fed into both the working path and the protected path. Both of these paths are received at Node A. Only one of them will be selected and fed to the output of the tributary. If one of the traffic paths fails to make it to Node A because of fiber cuts or other problems, the path selector inside of Node A will switch to the active path. Each tributary in the node has a path selector associated with it. **The path selectors are independent of each other.**

**If all the tributaries are E1 and all are provisioned with path protection, the maximum add/drop capacity of the whole STM-1 ring is 63 E1**

**Who:**

This configuration is useful to clients wanting full path protection in a ring topology.

**Add/Drop Capacity:**

63 E1's with SNCP/UPSR protection (The limit determined by the bandwidth of the STM-1 aggregate line);

**Advantages:**

Two fibers only; well protected against fiber cut

**Cost of Advantages:**

Ring topology is a must.

## Configuration 4: Ring Topology without SNCP Protection

### STM-1 Ring without Path Protection

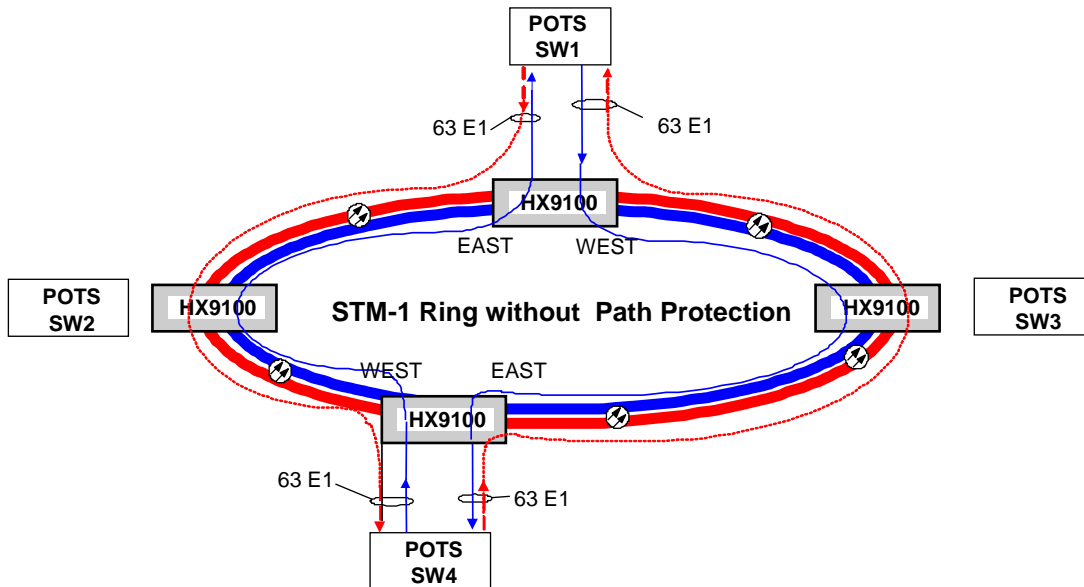

#### Operation:

This application assumes a case where there is a traffic flow of more than 63 E1's between POTS Switch 1 and POTS switch4. The E1 tributary adding to or dropping from the HX 9100 can be set up in a way that **no** SNCP/UPSR protection is configured. Theoretically, the maximum capacity between POTS SW1 and POTS SW4 is 126 E1's without SNCP/UPSR dual-feed protection in a ring topology like this. 63 E1's travel through the EAST side, while the other 63 E1's travel through the WEST side. When there is a fiber cut anywhere in the ring, half of the traffic between SW1 and SW4 will be gone, while leaving the other half of it unaffected. This approach will provide another form of protection, implicit protection, **if the switches or end equipments can still work with half of the traffic is gone.**

This implicit protection scheme can be achieved through careful network planning. The traffic between any two nodes could be separated into two groups. Each of them is deliberately directed to a different route to achieve the implicit protection goal. This configuration is good in terms of both maximum capacity and implicit protection. Owing to the limit of 4 E1 cards available on the O9100, the maximum number of E1s added to or dropped from a node is 112 (4x28), instead of 126 .

#### Who:

This configuration would be useful to clients who are prepared to achieve a maximum capacity of 112 E1's in a ring topology.

#### Add/Drop Capacity:

112 E1's without protection (Theoretically, the A/D capacity is 126 E1's. Due to the limitation of the numbers, 4, of E1 cards, the maximum capacity will be  $4 \times 28 = 112$ );

#### Advantages:

Two fibers only; maximum number of E1's is 112

#### Cost of Advantages:

Ring topology is a must. Half of the traffic will be affected when fiber cut.

## Configuration 5: Ring Topology With and Without Protection

### **Operation:**

It is possible to set up an HX 9100 network that combines [Configuration 3](#) and [Configuration 4](#) in a ring topology where the client can determine what to protect and what not to protect. The advantage of this system is that vital traffic flow can be protected (at a cost of otherwise available E1s) but other paths or lines can be left unprotected and thus fully utilized to carry non-vital traffic. This way, the client protects what needs to be protected, and gains back some capacity in the unprotected areas. It is a flexible network well suited to the needs of some clients.

### **Who:**

This configuration would be useful to clients who needs more than 63 E1's throughput. While still staying with this STM-1 ring, they are prepared to have mixed traffic types, some with explicit SNCP/UPSR protection and some without.

### **Add/Drop Capacity:**

63 to 112 E1's (The limit is determined by the number of E1 cards);

### **Advantages:**

Two fibers only; adding/dropping more than 63 E1's per node;

### **Cost of Advantages:**

Ring topology is a must. Half of the traffic without protection will be affected when a fiber is cut.

## Configuration 6: Ring Topology with both MSP and SNCP/UPSR Protection

Double Protection with  
SNCP/UPSR & MSP

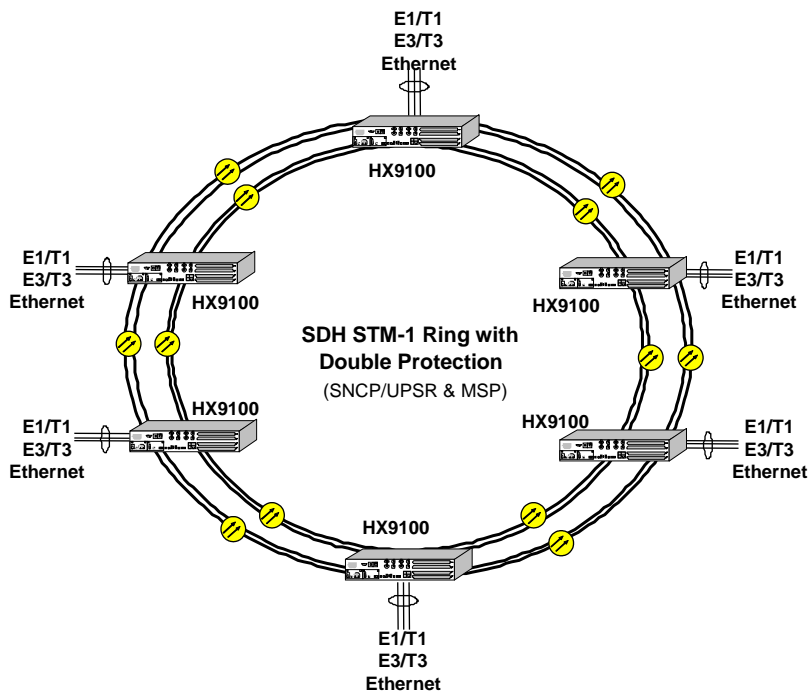

**Who:** This configuration would be useful to clients who need thorough protection against fiber cut and optical circuit pack failure.

**Add/Drop Capacity:** 63 E1's with double protection (The limit is determined by the bandwidth of the STM-1 aggregate line);

**Advantages:** Double protection is provided by SNCP/UPSR and MSP;

**Cost of Advantages:** Ring topology is a must. 4 fibers are necessary.

Maximum Tolerance of Fiber-Cut in Configuration 6

Double Protection with  
SNCP/UPSR & MSP

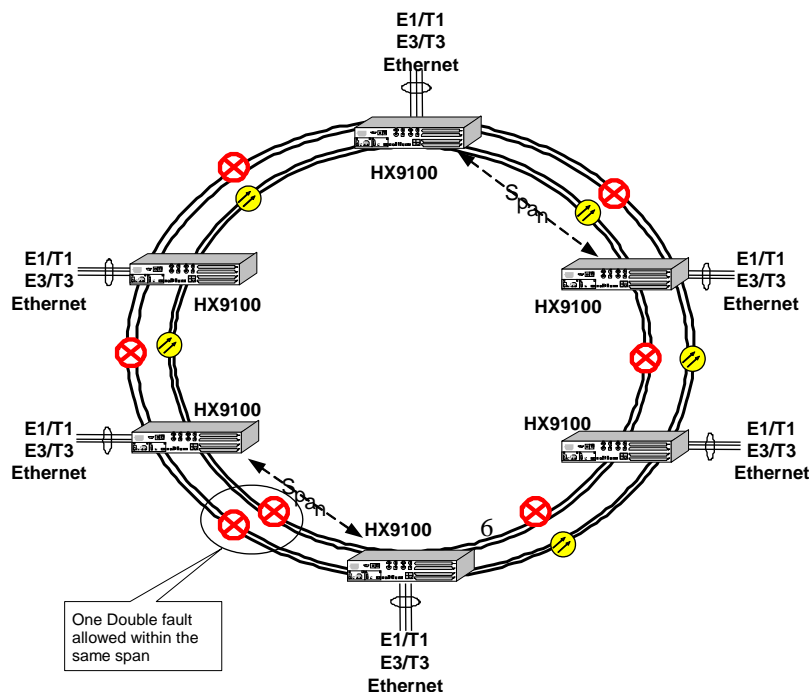

## Configuration 7: Ring Topology with MSP Protection

Ring with MSP Protection

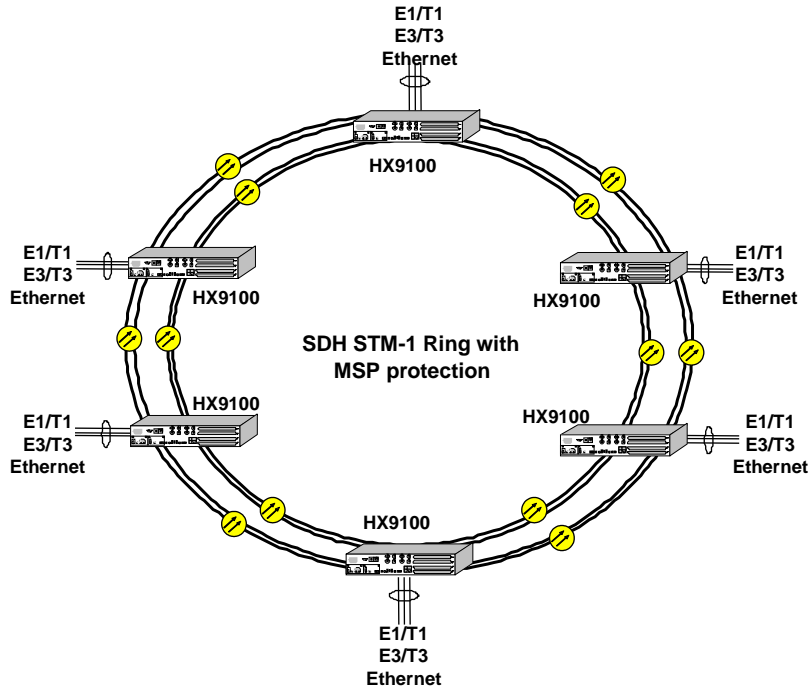

### Who:

This configuration would be useful to clients who need 112 E1's add/drop capacity and still enjoy MSP protection.

### Add/Drop Capacity:

112 E1's without protection (Theoretically, the A/D capacity is 126 E1's. Due to the limitation of the numbers, 4, of E1 cards, the maximum capacity will be  $4 \times 28 = 112$ );

### Advantages:

Maximum bandwidth (112 E1's) and MSP protection at the same time.

### Cost of Advantages:

Ring topology is a must.  
4 fibers are necessary.

Maximum Tolerance of Fiber-Cut in Configuration 7.

### Ring with MSP protection

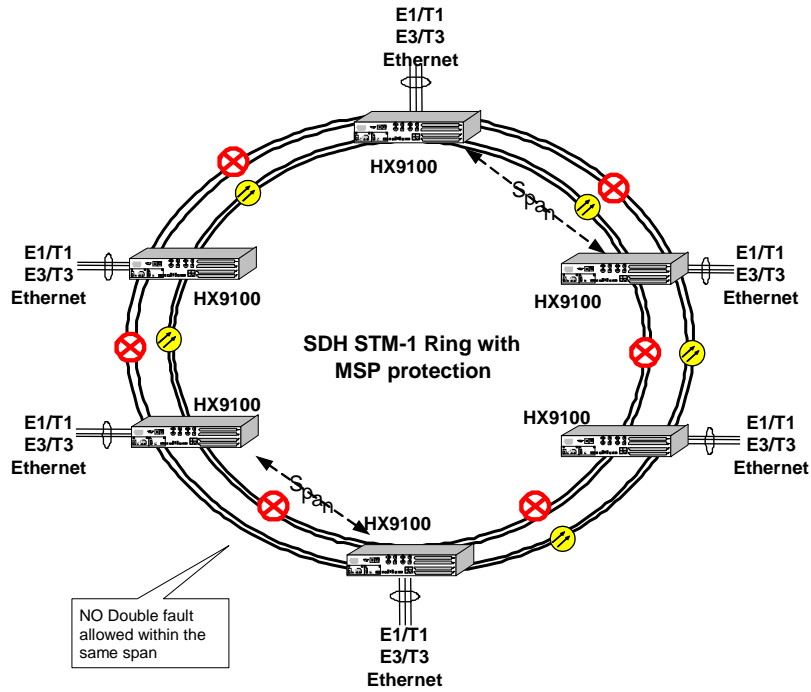

CXR Anderson Jacobson  
Rue de l'Ornette  
28410 Abondant - France

T +33 (0) 237 62 87 90  
F +33 (0) 237 62 88 01  
email: [contact@cxr.com](mailto:contact@cxr.com)



[www.cxr.com](http://www.cxr.com)  
Smart Solutions for Smart Networks